

Receiver For Remote Controller JS05

JS05 is necessary if you use wireless controller for duct type IDU and fresh air processing IDU.

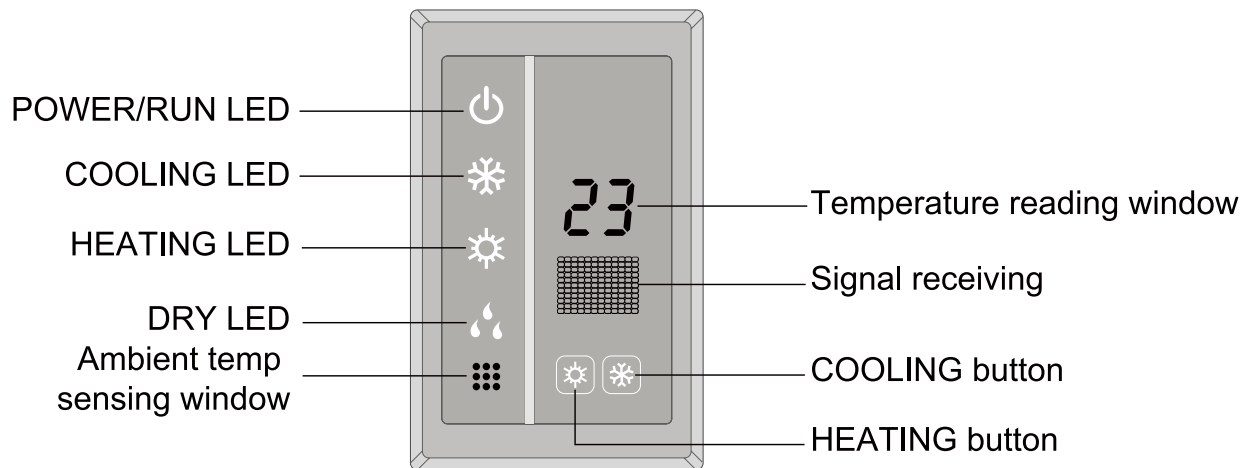

Five indicating LEDs listed below:

Operation \ LEADS	POWER (red)	RUN (red)	COOLING (white)	HEATING (white)	DRY (white)
COOLING	OFF	ON	ON	OFF	OFF
HEATING	OFF	ON	OFF	ON	OFF
DRY	OFF	ON	OFF	OFF	ON
FAN	OFF	ON	OFF	OFF	OFF
OFF	ON	OFF	OFF	OFF	OFF

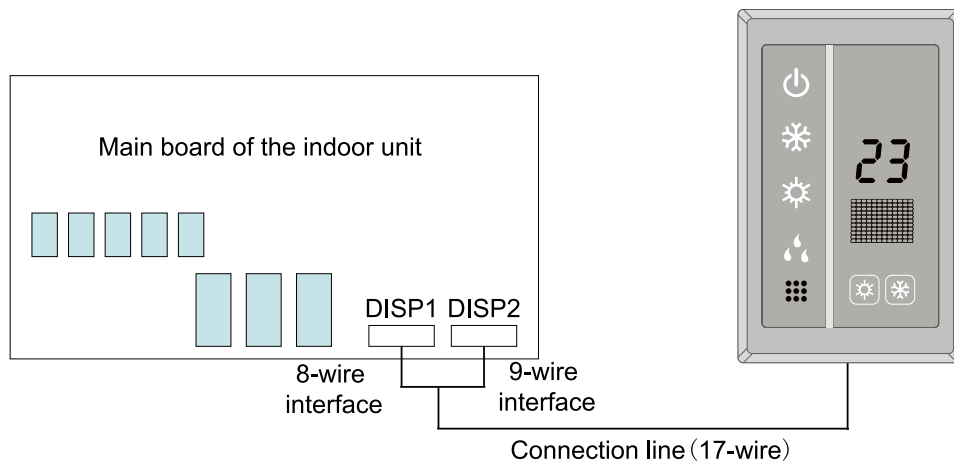

Job Name:		Date:	
System Reference No.:			
Engineer Signature:			

Outline and Physical Dimensions of JS05.

Unit: mm(inch)

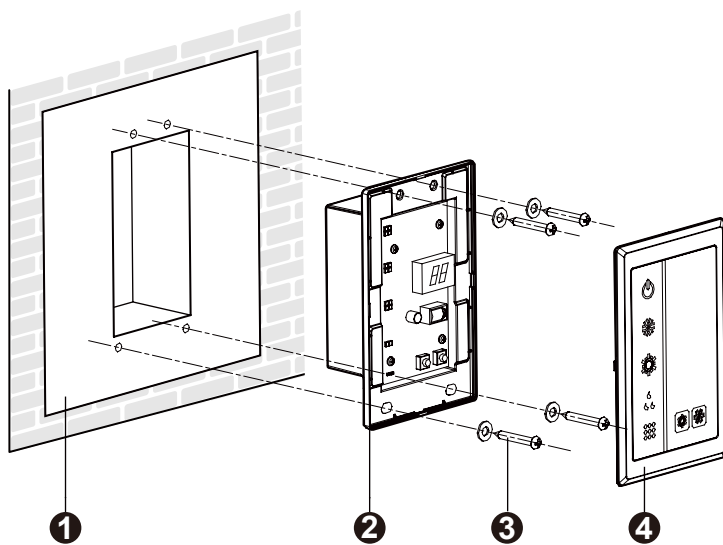
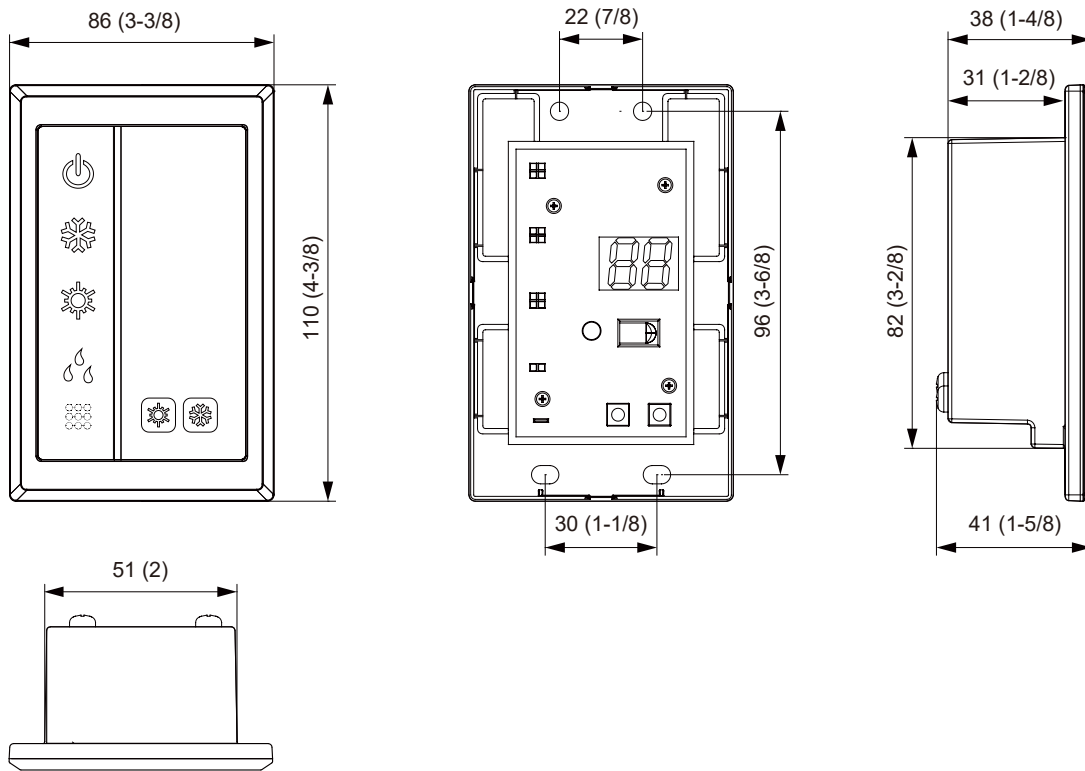

No.	Description
1	Wall or ceiling
2	Receiver with the front panel removed
3	Screws or washer
4	Front panel